



Motorola Wireless Broadband Point to Multipoint (PMP) Wireless Access Networks System Design Guide

A large, light gray decorative graphic consisting of several overlapping, rounded rectangular shapes and lines, resembling a stylized 'M' or a network diagram, is positioned on the right side of the page.

PURPOSE

The purpose of this document is to equip Motorola Wireless Broadband System customers with the information needed to effectively plan a wireless network.

This document is designed for general use. It is permissible to extract certain sections or subsections that apply to specific customer situations and incorporate them into sales collateral materials. This document should not be used for contracts or proposals in lieu of an official Motorola customer document. All information is subject to change.

Motorola Wireless Broadband Solutions

Motorola's industry leading portfolio of reliable and cost effective wireless broadband solutions provide and extend coverage both indoors and outdoors. The Motorola Wireless Broadband portfolio offers high-speed connectivity systems that support data, video and voice solutions enabling a broad range of applications for public and private networks. With Motorola's innovative software solutions, customers can now design, deploy and manage their broadband networks at lower installation costs that maximize up-time and reliability.

What Makes Motorola Wireless Access Network Solutions Different

- **Industry Leading Interference Tolerance** – Motorola access network solutions designed to operate in the unlicensed spectrum include GPS synchronization to mitigate self interference and have the best Communication to Interference (C to I) ratio.
- **Fast, Simple Installation** – Access points and subscriber modules are all Powered over Ethernet (PoE) and require no equipment room or environment controlled area at the tower location.
- **Reliable Hardware Performance over Time** – Motorola access network solutions perform in harsh weather conditions including heat, cold and moisture. Designed without heaters or cooling fans, Motorola equipment performs with less than 1% hardware failures.
- **Field Throughput Performance Meets Expectations** – Network equipment performance specifications are statements of actual field performance, not performance in an indoor noise free lab environment.
- **Scalable as Subscriber Base Grows** – GPS synchronization enables network operators to build dense networks in close quarters without interference, enabling service providers and enterprises to build reliable, cost effective connectivity.
- **Proven Access Network Connectivity** – With more than 4,000 networks using Motorola PMP access networks world wide and millions of modules installed, reference architectures and case studies are available to aid network design.
- **Proven as Infrastructure for Mesh Network** – PMP access networks are deployed as an infrastructure capacity injection layer for mesh network technology.
- **Attractive Total Cost of Ownership** – Technology is the means to business success. With a portfolio of wireless access network solutions, network operators can select the solution that best meets the needs of their business case over the long term.

What's New for 2009?

Motorola continues to invest in Point to Multipoint access networks by adding new capabilities to dramatically expand the portfolio of options for network operators:

- **Licensed OFDM Solution** – The PMP 500 series provides OFDM based high speed throughput at 3.5 GHz.
- **OFDM Solution at 4.9 GHz** – The field proven PMP 400 series with OFDM high speed connectivity is now available at 4.9 GHz.
- **OFDM Solution at 5.7 GHz** – The field proven PMP 400 series with OFDM high speed connectivity is scheduled to be available in late 2009 at 5.7 GHz.
- **One Point Wireless Suite** – Network operators can now use one common element management system across the Motorola portfolio of wireless broadband solutions to perform network design, streamline deployment, and manage networks.
- **Horizontal Polarization Modules** – PMP 100 and 200 series access network equipment at 5 GHz is now available with either vertical or horizontal polarization to enable network operators to select the polarization that best meets their performance requirements.

Motorola Wireless Broadband Solutions

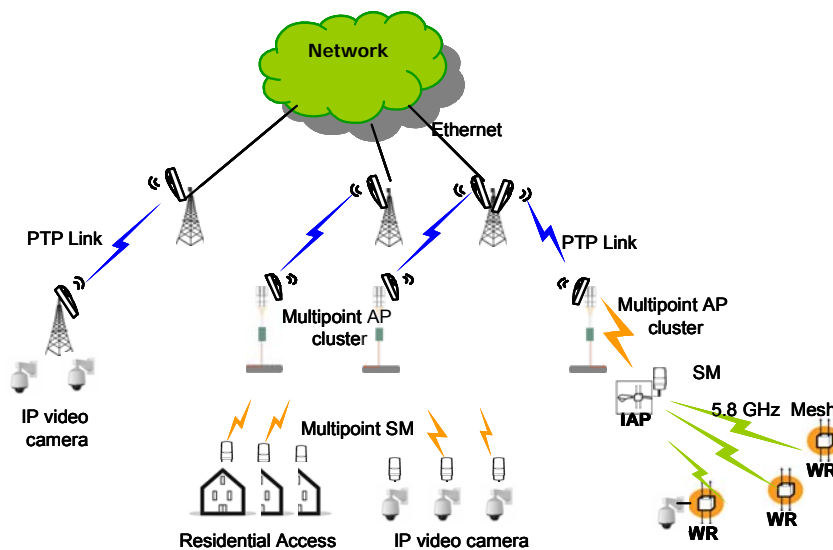

Figure 1: Motorola Wireless Broadband Solutions

Motorola's Wireless PMP Access Networks

Motorola point-to-multipoint access network solutions enable cost-effective, reliable, and secure connectivity in thousands of networks in more than 150 countries today. Serving a broad range of licensed and unlicensed spectrums (with solutions at 900 MHz through the 5 GHz frequencies), the PMP solutions are designed for even the harshest of outdoor environments to provide high-speed voice, access and data services.

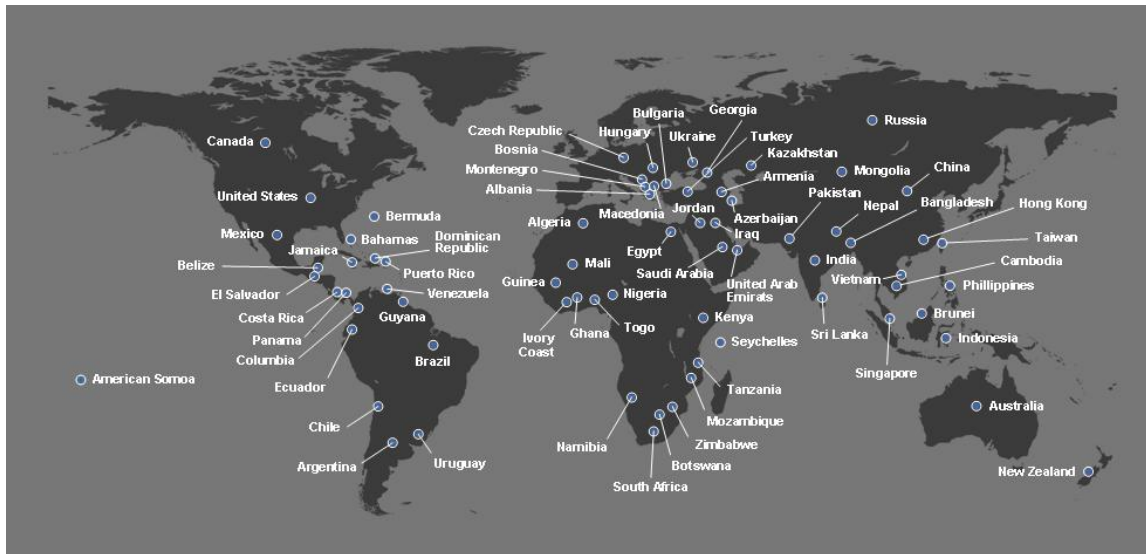

Figure 2: Motorola Wireless Access Networks Deployed Around the World

Reliable, Cost Effective Wireless Data, Video and Voice Connectivity

Motorola's innovative wireless broadband access network solutions are the ideal technology for delivering high-demand technologies such as broadband Internet access, video services, security surveillance, voice over IP and E1/T1 connectivity. Motorola wireless broadband technology combines field proven toughness with exceptional performance, security, ease-of-use and cost effectiveness. It significantly reduces the time to design and deploy new commercial and enterprise broadband networks. It also seamlessly integrates with existing network systems and management tools to make extending and augmenting existing service simpler and less cost-intensive.

Motorola wireless broadband access networks offer one of the lowest total costs of ownership in the industry, and can deliver a proven business case providing a ROI in just six to twelve months. With Motorola's 80 years of radio knowledge, experience and leadership, dedication to creating and maintaining trusted relationships over the long-term access network operators are assured high levels of worldwide service and support as their networks grow over the years.

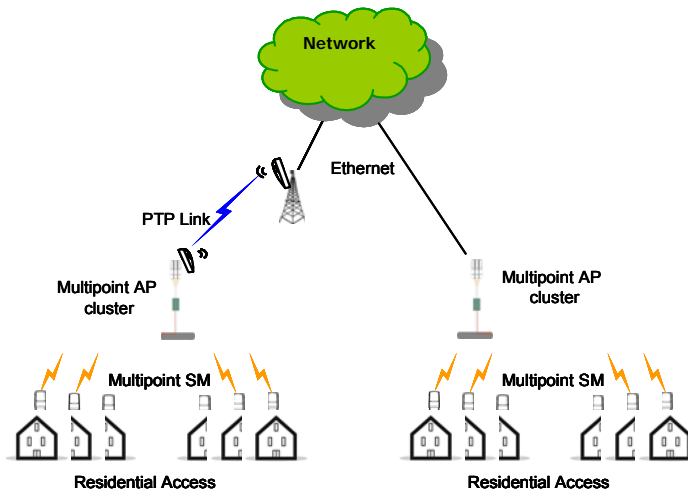

Figure 3: Motorola Wireless Networks Used for Residential Access

Wireless Access Networks

Motorola wireless access networks are one part of a total Broadband Wireless Access (BWA) solution for extending the existing network to provide broadband services to new users. The system provides a wireless Ethernet connection which can be used to transport data, video and voice in channelized or unchannelized formats. Modules are available to support Line of Sight (LOS) and Non-Line of Sight (NLOS) point-to-point links and point-to-multipoint last mile access solutions. With a broad array of Backhaul (PTP module), Access Point (AP) and Subscriber Modules (SM), and mesh access modules, the system can be configured to meet the current and future needs of business and residential network users.

Sources of additional information are listed on the last page of this document.

Benefits of the Motorola wireless broadband access networks

- **Service providers can enhance their customer base and revenues** by extending the network to reach new business and residential subscribers beyond the reach of wireline broadband offerings.
 - Complement existing broadband network to reach customers in new territories, whether adjacent to an existing network or a completely new region
 - Offer wireless broadband services to existing subscribers currently using dial-up; alternative to other equipment like DSL and cable
 - Extend network geography into new, underserved areas
 - Rapidly mass-deployed, value-based broadband
- **Enterprises can establish cost-effective links** to campus locations or remote branch offices at a fraction of the cost of leasing lines or deploying wireline broadband systems.
 - Rapid access to business information between locations
 - Cost-effective; substantially less than cost of leased-line alternatives – no recurring monthly fee
 - Wireless infrastructure to connect indoor wireless local area network (WLAN), creating a completely wireless IP network and connecting inside to outside
- **Government Network Operators can establish cost-effective links** for public safety, public service, and public access.
 - Rapidly deploy video surveillance and data connectivity for public safety
 - Create a cost effective data network for public works
 - Create an infrastructure for community wide public access

Applications

Motorola wireless broadband access networks can be used to complement DSL, Cable, Fiber and other wireless networks or used in stand alone configurations.

- **Data Transfer**

Motorola solutions bring powerful radio technology to enterprise communications applications, making deploying and delivering low-cost broadband access faster and easier than ever before. They provide the performance, versatility, ease-of-use and affordability that enable enterprise environments—including corporate, municipal, healthcare, education and more—to improve communication, productivity, security and return on investment (ROI).



- **Video -**

IP-based video surveillance is revolutionizing the way organizations, municipalities and institutions are protecting their property, personnel and proprietary assets. Motorola is an industry leader in wireless video surveillance solutions for public safety. Motorola's proven wireless broadband technology helps network operators and their customers join the revolution. Compared to analog or hybrid systems, IP-based solutions provide a number of crucial advantages, including:



- Real-Time Situational Awareness and Response
- Remote Monitoring and Accessibility
- Faster, Lower Cost Deployment
- Leverage the Existing Networks
- Maximize the Benefits of Smart Cameras and Software
- Optimized ROI
- Digital Image Encryption for Security Purposes

- **Voice**

Access network modules can be used to transport Voice over IP (VoIP) services as a PBX extension when IP phones and typical hubs are used at the customer premises.



Key Attributes of the Motorola Wireless Access Networks

In today's crowded broadband communications marketplace, no system can match Motorola access networks' combination of advanced technology, simplified configuration, rapid deployment and remarkable cost effectiveness. Motorola solutions enable Internet Service Providers (ISPs) to differentiate, create competitive advantage and attract and please increasingly demanding residential and business customers, even in hard-to-reach areas.

Simple Network Design

The PMP system's intelligent protocols streamline deployment and operation. A simple network design allows the system to complement the existing network, and makes it exceptionally easy to install. The equipment is intuitive and efficient, providing built-in installation and deployment assistance that makes it faster to get up and running... often in a matter of hours or days instead of weeks or months.

Superior Performance

Motorola access network solutions deliver superior performance using a modulation scheme that improves the quality of data delivery and mitigates interference from other systems. The system's wireless signals are highly effective in penetrating obstacles and avoiding obstructions, making it as efficient in dense urban environments as it is in suburban areas or rural locations. The platform provides last mile access in a variety of spectrum choices, ensuring exceptional broadband performance no matter which spectrum is best for network performance.

Exceptional Security

The platform also offers security with over-the-air DES (Data Encryption Standard) encryption and is also available with AES (Advanced Encryption Standard) capabilities, which provide 128-bit encryption, to ensure secure data delivery and exceptional reliability.

Satisfying Speed

The point-to-multipoint access network offers speeds from 512 Kbps to 21 Mbps (aggregate data rates) and the Motorola point-to-point bridges deliver from 7.5 to 300 Mbps (aggregate data rates) to network users. Of course, upload and download speeds are affected by several factors so actual speeds may vary, but the potential to offer an incredible broadband experience can be designed into the system deployment.

Interference Tolerance

Because of its signal synchronization, Motorola wireless access network solutions offer a high level of tolerance to self-interference. The system provides reliable service even when the APs are placed close together.

Scalability

Motorola access networks scale to meet network growth so that throughput remains consistent as new subscribers are added to the network.

Return on Investment

Low infrastructure costs and wireless last mile connectivity yield a payback in terms of months. Motorola is glad to provide detailed case studies of customers who have successfully deployed wireless broadband equipment in a variety of applications. Refer to the last page of this document to access a list of successful deployments.

Flexible Configuration Options

Motorola solutions include configuration options that meet and exceed both provider and customer expectations. The platform can be configured as a single-site point-to-multipoint system that supports subscribers for distances up to 15 miles (24 kilometers). The Motorola point-to-point series of wireless Ethernet bridges increase delivery range up to 124 miles (200 kilometers). In addition, the system includes interfaces that enable it to easily integrate with standard network management tools and billing systems, as well as diagnostic capabilities needed to remotely monitor the network.

One Point Wireless Suite

An innovative and powerful set of solutions that enable you to design, deploy and manage your wireless broadband indoor and outdoor networks including Motorola indoor WLAN, outdoor MOTOMESH, Point-to-Multipoint and Point-to-Point products. One Point design tools yield highly accurate outdoor link and indoor 802.11b/g/n network designs which provide optimal coverage and capacity the first time. The Motorola Wireless Manager gives you a single point of control for your indoor and outdoor wireless broadband network and includes a new level of visibility through real-time, highly advanced network visualizations in an embedded Google maps environment.

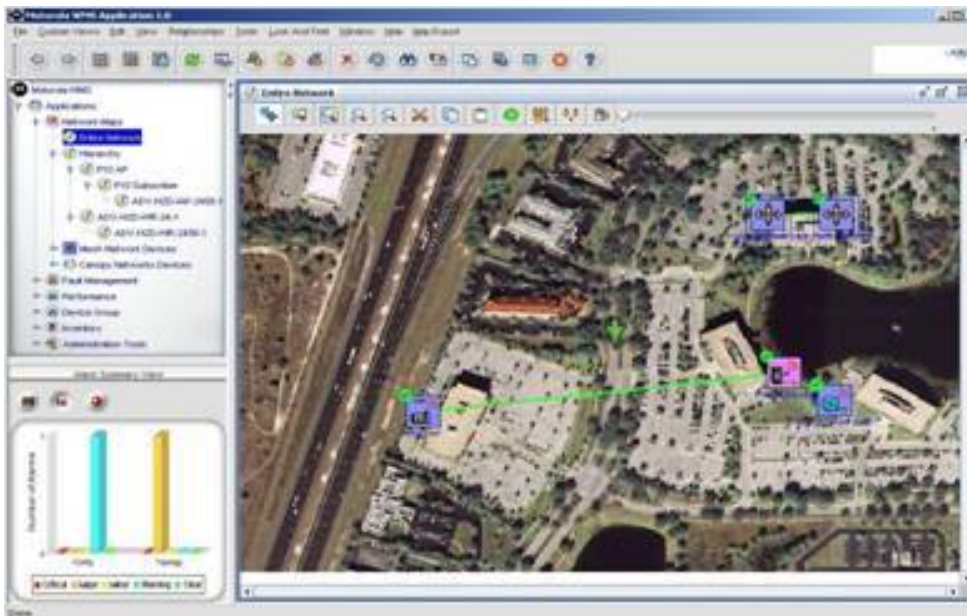
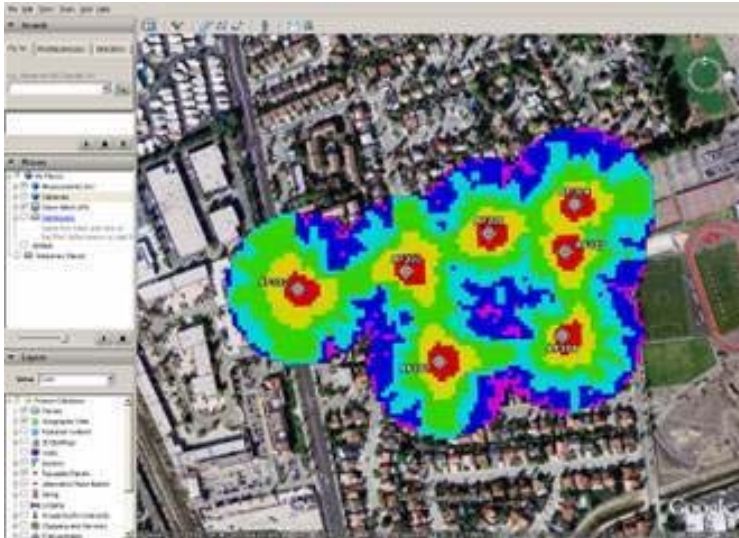

Figure 4: Screen Examples of the Motorola OnePoint Wireless Suite

Licensed and Unlicensed Solutions

Motorola wireless access network solutions include products that use the licensed and unlicensed spectrum. Licensed solutions are optimized for speed and throughput as they will not normally encounter noise and interference due to license regulations. Unlicensed solutions have been designed from the ground up to optimize interference tolerance. With GPS synchronization, they provide superior performance in areas where there is noise in the spectrum. These solutions can be deployed as an access network, or as a capacity injection layer for other last mile solutions.

AP and SM

The Access Point Module (AP) distributes network or Internet services in a sector for as many as 200 subscribers. The AP is configurable through a web interface. The Subscriber Module (SM) is a Customer Premise Equipment (CPE) device that extends network or Internet services by communication with an AP. The SM is configurable through a web interface.

	500 Series	400 Series	200 Series	100 Series
Typical Application				
Residential	✓	✓		✓
Enterprise	✓	✓	✓	✓
Government	✓	✓	✓	
Performance				
Line of Sight	✓	✓	✓	✓
Near Line of Sight	✓	✓		
Non Line of Sight	✓	✓		
Standards				
Interoperable with 802.16e CPE	future			
Proprietary	✓	✓	✓	✓

Table 1: Functionality of Motorola PMP Systems

Access Points are available in a wide range of frequencies from 900 MHz to 6 GHz. These modules are available with integrated antennas for ease of installation, and some are available with connectorized versions to enable network operators to configure their network to meet their specific requirements. AP's are also available with higher performance options to provide higher throughput and NLOS connectivity.

Access Points				
	Unlicensed	Licensed	Speed Mbps	NLOS
CAP 500 Series (90 degree sector)		Y	13.5	Y
CAP 400 Series (90 degree sector)	Y	Y	21	Y
CAP 200 Series (60 degree sector)	Y		14	
CAP 100 Series (60 degree sector)	Y		7	

Table 2: PMP Access Point (AP) Modules





			
100 Series AP Cluster	200 Series AP Cluster	400 Series AP	500 Series AP

Table 3: PMP Access Point (AP) Modules

Subscriber Modules are Customer Premise Equipment (CPE) equipment at the subscriber location. These modules are simple to install and can provide connectivity for a single device or a downstream access WLAN network. SMs are available in a wide range of frequencies for 900 MHz to 6 GHz. These modules are available with integrated antennas for ease of installation, or are available with connectorized versions to enable network operators to configure their network to meet their specific requirements. 900 MHz SMs have an Indoor option. SMs can be equipped with passive range extenders to boost performance to establish connectivity to distant locations. SM's are also available with higher performance options to provide higher throughput and NLOS connectivity. Power Supplies and mounting brackets for SMs are sold separately.







			
100 Series SM	200 Series SM	400 Series SM	500 Series SM
			
900 MHz Indoor SM	900 MHz Outdoor SM	100/200 Series SM with Passive Reflector	

Table 4: PMP Subscriber Modules (SM)

Element Management

Prizm element management software allows network operators to

- distribute bandwidth
- manage authentication
- monitor network performance

Cluster Management Module (CMM)

The Cluster Management Module provides GPS synchronization to the AP and all associated SMs. The CMMmicro or CMM 4 provides power, GPS timing, and networking connections for an AP cluster. One CMM can communicate with a variety of different AP modules located at the same tower. If the CMM is also connected to a PTP module, then the CMM is the central point of connectivity for the entire site. The CMM can connect as many as eight collocated modules and an Ethernet feed.

Power Connection and Cables

The PMP system is typically installed on outside infrastructure platforms such as radio towers and roof top locations. Motorola recommends the use of shielded outdoor cables that adhere to Category 5 and 5e standards for the installation of AP, PTP and outdoor SM modules.

Coverage Extender

The Coverage Extender provides simple, high performance expansion of a Motorola wireless access network to serve potential end-customers outside of current wireless coverage range. The Coverage Extender enables service providers to deliver reliable data, video and VoIP service in areas that previously could not be cost effectively covered. These potential customers may simply be located beyond the line-of-sight (LOS) of the Access Point (AP) or AP cluster, or within range, but in a coverage dead-zone, blocked by manmade or natural obstructions.



Passive Reflector

The 27RD Passive Reflector Dish extends the distance range of a module and focuses the beam into a narrower angle. The internal patch antenna of the module illuminates the Canopy Passive Reflector Dish from an offset position. The module support tube provides the proper angle for this offset.



LENS

The LENS passive module enables service providers to provide reliable data, video and VOIP services in areas that could not previously be reached due to range limitations. By increasing the range and focusing the antenna beam, the LENS allows service providers the ability to reach more subscribers and results in a reduction of external RF noise. This compact yet durable product easily mounts directly onto existing 100 and 200 series modules and requires no additional mounting hardware.



Surge Suppressor

The 200SS or 600SS Surge Suppressor provides a path to ground (Protective Earth) that protects connected subscriber home equipment from near-miss lightning strikes.



Point-to-Multipoint Access

Throughput and Range

The Motorola wireless broadband access network with its hundreds of engineering years of design, more than 60 patents, and hundreds of commercially deployed networks in more than 150 countries, has the proven design to truly deliver Broadband Wireless Access for all applications. Designed from the ground up to optimize consistent performance across the network, the PMP system has been proven to provide reliable throughput to all network users in the following cases:

- Small and large number of subscribers in the network
- Subscribers located both near to and far from the Access Point location
- Network carrying varying types of traffic

Operating range and data throughput are dependant on many factors including: terrain, foliage, background RF energy, and other conditions. PMP system modules are designed to provide reliable communication with a minimal difference in throughput as distance increases and as subscribers are added to the network. The system's unique signaling technique provides a consistent data rate and throughput to users across the entire service area.

Access Networks

Motorola wireless Access Points and Subscriber Modules comprise the access network. APs are the distribution head end and each one serves up to 200 subscribers. APs can be clustered in groups providing coverage for a community of subscribers. SMs are installed at the subscriber location.

The new Canopy 400 and 500 Series AP and SM products provide near-line-of-sight (nLOS) and non-line-of-sight (NLOS) performance through the use of OFDM technology, longer cyclic prefixes, and higher gain antenna solutions. The improvement is seen most in multi-path environments where the signal is reflected off other buildings and objects. Improvements in penetration of foliage are also possible. In general, OFDM technology improves performance in near- and non-line-of-sight environments. This makes it possible to provide connectivity in areas where trees or other items may be present.

Network Infrastructure

A wireless access network can also be deployed as an infrastructure to provide bandwidth to an access last mile application. PMP networks can supply connectivity for WiMAX, WLAN, mesh and other networks as shown below.

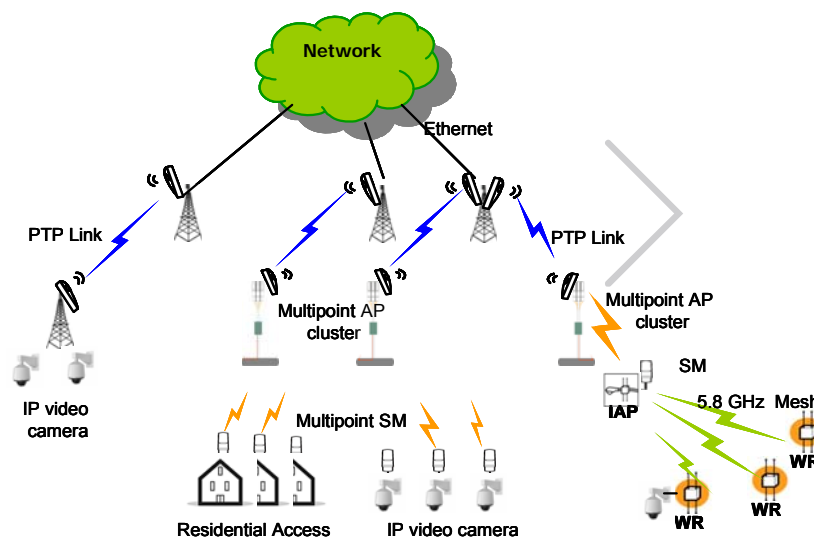

Figure 5: Motorola Wireless Broadband Solutions Provide Access and Video Surveillance

In addition to standard configurations with the AP at the distribution head end, the PMP system architecture supports remote AP configurations, where an AP is co-located with an SM to provide for remote distribution and increased network extensions. This technique is useful in two deployment situations:

- Extend range and coverage
- Get under the tree line and distribute the signal to a cluster of customers in an area

Motorola wireless broadband access network system modules are available in different frequencies to afford flexibility in network design and allow equipment selection for the best RF solution for each individual service area. In addition, passive reflectors are available for most Subscriber Modules to provide extended range capabilities to reach remote subscribers and also reduce interference by creating a smaller beam pattern.

Below is a sample chart of the different products available, their typical applications and features.

	500 Series	400 Series	200 Series	100 Series
Typical Application	Government and Enterprise connectivity	Enterprise and/or Residential broadband services	Residential and/or Enterprise broadband services	Residential and/or Enterprise broadband services
Total Aggregate Throughput	13.5 Mbps	21 Mbps	14 Mbps	7 Mbps
Environment	Fixed Licensed	Fixed Unlicensed	Fixed Unlicensed	Fixed Unlicensed

Table 5: PMP Systems Performance Overview

	500 Series	400 Series	200 Series	100 Series
900 MHz			•	
2.4 GHz			•	•
3.5 GHz	•			
4.9 GHz		•		
5.1 GHz			•	•
5.2 GHz			•	•
5.4 GHz		•	•	•
5.7 GHz		○	•	•
6.0 GHz			•	•

Table 6: PMP Systems are Available in Multiple Frequencies
(Future release indicated with O)

Polarization Options

Motorola offers 5 GHz modules with either vertical or horizontal polarization. Polarization can provide isolation from ambient noise in the operating area. Network operators can select the signal polarization that best meets the needs of their environment.

Performance

Motorola wireless broadband access networks gracefully scale to support large deployments. The system's GPS synchronization allows network operators to re-use frequencies within a geographic area and add capacity while consistently ensuring consistency in the quality of service to customers. As a result, subscribers can experience consistently reliable service. The system's unique signal modulation technique yields an industry-leading nominal Carrier to Interference (C/I) ratio of less than 3 dB and ensures reliable communication when other transmitters are present.

Noise Filters

900 MHz is a crowded frequency. Band pass filters are available as an option to reduce the out of band noise received. The following chart will aid in deciding whether to use a filter for 900 MHz installations. The Canopy system now offers 2 channel and 3 channel filters, depending on which frequencies are desired to be used.

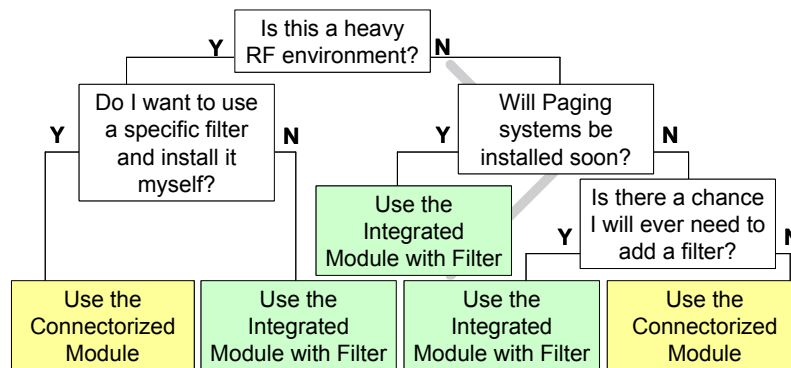

Table 7: Decision Matrix for Using a Filter with Series 200 900 MHz Equipment

Connecting the AP to the Network

The system appears to the network like a layer 2 bridge and is transparent to layer 2 protocols. The AP is connected to the network via a UV rated CAT 5 cable approved for outdoor applications. Where more than one AP is installed in a cluster, a Cluster Management Module (CMM) will distribute and synchronize the signals of the AP cluster.

Cables

Proper cable and cable connections are critically important to ensuring the proper performance of the access network. The PMP system is typically installed on outside infrastructure platforms such as radio towers and roof top locations. Motorola recommends the use of shielded outdoor cables that adhere to Category 5 and 5e standards for the installation of modules.

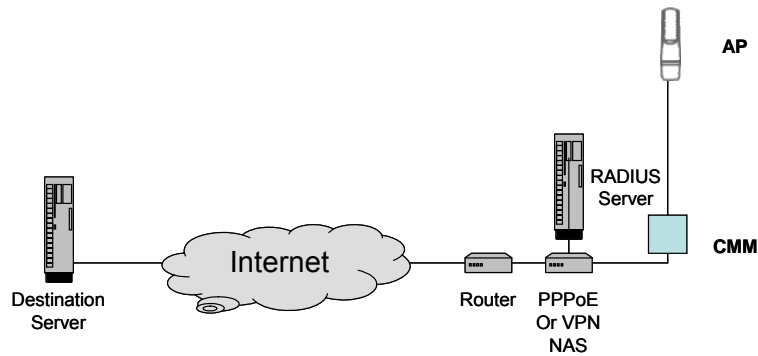

Figure 6: Wireless Access Network Connections at the Network Center

Point-to-Point Wireless Bridges - Overview

Motorola offers a selectivity of wireless bridges at a number of frequencies. PTP modules are simple to install. PTP link installation can often be completed within a few hours, saving valuable time and expenses. There is no need to work out right-of-way issues or wait for costly network build-outs. Many of the backhaul modules are available with passive reflectors to extend range.

Applications:

- High throughput connection to backhaul voice, video and data
- Backhaul for WiMAX base stations
- Extend channelized T1/E1 services over a long distance
- Interconnect campus buildings and remote branch offices
- Reach remote AP clusters
- Extend PBX circuits
- Backhaul to Cellular sites
- Provide secure stand-alone network
- Cost effective backhaul link to reach AP clusters
- Remote Security surveillance

The Return on Investment (ROI) is a matter of months because PTP links provide a permanent solution at a fraction of the cost of leased line alternatives.



	Unlicensed	Licensed	Speed (Mbps)	NLOS
100 Series	Y		7 / 14	
200 Series	Y		21	Y
300 Series	Y		25	Y
500 Series	Y		52 / 105	Y
600 Series	Y	Y	150 / 300	Y

Table 8: PTP Portfolio Overview

Putting the Motorola Wireless Access Network in Service

Wireless access network modules can be combined to tailor the network to meet current and emerging needs. As demand grows over time, new modules can be added to support network extensions or to add capacity to backhaul links.

Step 1 – Perform Site Survey

A site survey includes both a physical and a radio frequency analysis of the area where the network is to be installed.

Physical Survey Issues:

- availability and height of tower locations
- estimate of coverage area
- type and density of foliage
- geographic conditions, including man made structures
- environmental conditions including seasonal changes

RF Survey Issues:

- spectrum analysis of the geographic area at desired frequency
- spectrum analysis at alternative frequencies
- polarization of signals
- anticipated changes in local RF conditions

Step 2 - Select Reference Architecture

After considering goals and business strategy, select from the reference architectures in this document the ones that most suits the business requirements. If the network includes diverse markets, a combination of reference architectures may be the most appropriate solution.

Motorola wireless broadband access networks are deployed in more than 150 countries, and trained Motorola account managers, distributors and resellers will help design a network that best meets current and future requirements.

Step 3 - Network Design and Deployment

From the network specific architecture, detailed equipment requirements are developed. The network is engineered and module locations are verified.



The following aspects need to be fully considered:

Aspect	Explanation
<p>Bandwidth Distribution</p>	<p>The aggregate throughput requirement for each AP needs to be considered. This includes all downlink data to all subtending SMs and all uplink data from all SMs that link to the particular AP.</p> <p>While a single AP can communicate with up to as many as 200 SM's, keep in mind that the aggregate throughput is distributed across the SMs that are actively getting data simultaneously.</p> <p>Where a PTP module is co-located with an AP cluster, the total throughput of the AP cluster should be used to determine the bandwidth requirement for the associated PTP module link.</p> <p>For PTP modules, the aggregate throughput on the channel also needs to be considered in network design. If a PTP module is set to a downlink ratio of 50%, then the bandwidth in each direction is half of the total PTP module link bandwidth.</p>
<p>Network Design</p>	<p>Before diagramming network layouts,</p> <ol style="list-style-type: none"> 1) Anticipate the correct amount of signal loss for link budget calculation. Motorola provides the antenna gain, receiver sensitivity, EIRP power level for each module. Use this information to determine the range of the system in a specific network application. 2) Recognize all significant RF conditions. An RF signal in space is attenuated by Fresnel zones, atmospheric and other effects as a function of the distance from the initial transmission point. The further a reception point is placed from the transmission point, the weaker is the received RF signal. 3) Consider the specific site requirements: <ul style="list-style-type: none"> • Tower rights • Power availability • Temperature control 4) Evaluate potential sites by their fitness to address fade margin and ambient RF conditions. An essential element in RF network planning is the analysis of spectrum usage and the strength of the signals that occupy the spectrum planned for use.
<p>Network Management</p>	<p>PMP network elements are accessed through IP Version 4 (IPv4) addressing. Proper IP addressing method is critical to the operation and security of the network. For security, the network operator should either assign a private IP address, or assign a public IP address only if a firewall is present to protect the module. The PMP system allows selectable Maximum Information Rates (MIR) to provide data rates that meet customer requirements.</p>

There are many successful deployments of PMP networks which apply the strengths of the different modules to meet the specific requirements of the particular environment in which they are used. These networks use combinations of 2.4 GHz, 3.5, 4.9, 5.1, 5.2, 5.4, 5.7 and 6.0 GHz APs and SMs, complemented with 900 MHz modules to fill in the holes or difficult to reach areas of the network.

Network Design “Do’s”

Given the crowded bands in the unlicensed spectrum, there are some things that network operators can do to get the best advantage possible:

- Understand that the spectrum can be very congested with both in-band and out-of-band interference.
- Perform a spectrum analysis of the area from the location where the AP’s are intended to be mounted and mount the AP as high as possible where there is a clean RF environment.
- Use regulatory certified sectorized antennas where possible.
- Ensure that the equipment is configured properly with correct “max range” and “antenna gain” settings.

Network Design “Don’ts”

There are some key activities to avoid, and avoiding these will also help get the best advantage in operating the network successfully:

- Don’t use omni directional antennas if it can be avoided. Omni directional antennas are exposed to interference from every direction.
- If it can be avoided, don’t use vertical polarization for 900 MHz. Simply using horizontal polarization at this frequency is likely to reduce the noise level.
- Don’t set the “antenna gain” parameter with anything except the actual gain of the antenna. Other numbers may violate regulatory limits for power output.
- Don’t increase the value of the “antenna gain” parameter expecting it to increase power output.

Don’t expect filters to help with in-band interference. Band pass filters specifically eliminate out-of-band interference, but have no effect on in band interference.

Motorola and many of our distributors offer specific training for network operators to ensure that the PMP system is planned correctly and implemented properly. This training includes discussion of case studies in network deployment and development of a high level deployment configuration for a sample network.



PMP Network Management Capabilities

Element Management

The Element Management System provides network operators bandwidth allocation control to assign maximum data rates per subscriber including:

- Sustained Uplink
- Uplink Burst Allocation
- Sustained Downlink Data Rate
- Downlink Burst.
- In addition, the EMS is the central point of authentication in the PMP system. Complementing the PMP system's data encryption, the element management system provides an additional layer of security to restrict access to system data.
- RADIUS Authentication enables network operators to exchange information freely from the PMP system and therefore, will not need to maintain separate databases.
- Support for a Variety of Databases means that the EMS will work with more installed operations systems including RADIUS servers, or to a specific database through ODBC.

Network Management

- One Point Wireless Manager can be used to provide real-time monitoring of PMP, PTP, Mesh and indoor WLAN network performance in a unified Google maps-based view as well as performance trend analysis tools to localize any quality of service issues.

Security

- FIPS 197 Certified Advanced Encryption Standard (AES) encryption is a 128-bit encryption standard that meets the security requirements of federal, municipal, financial and health care institutions.
- DES (Data Encryption Standard) encryption that provides 56-bit encryption.
- BRAID Encryption - The AES key is encrypted by Motorola's 128-bit Telecommunications Industry Association (TIA) standard BRAID algorithm making it more secure than others in the market.
- Synchronization - The PMP system's unique synchronization technique provides higher security than 802.11 alternatives by requiring precise synchronization from all modules in the network.
- Authentication - PMP modules can be scheduled to periodically exchange a random number "challenge" to authenticate system users and keep out "rogue" modules.
- PTP 300, PTP 500 and PTP 600 units employ a built in proprietary signal with scrambling applied as an additional layer of security. In addition, this backhaul employs the following security levels:
 - Reed Solomon forward error correction
 - Scrambling code that repeats every eight Reed-Solomon code words (about 1 ms).
 - Interleaver where the signal is then changed in order
 - Convolutional Encoding where the signal is scrambled into two streams and then sent serially with some bits unsent.
 - Encoding into BPSK, QPSK, 16QAM or 64QAM waveforms
 - Interleaving across a 1024 carrier OFDM wave form.

Step 4 - Install and Verify Service

Properly planned, installation of the Motorola wireless broadband access network can be completed in a matter of hours. The PMP system includes detailed user interfaces to provide required information to the field technician. When necessary, the system also provides detailed diagnostic information to assist field technicians in the troubleshooting and repair process.

Motorola training includes modules on installation and repair and a hands-on lab where attendees work with live system modules to perform the installation and verification procedure.

Reference Architectures for Access Networks

The following reference architectures illustrate some of the applications that carriers have deployed using Motorola wireless broadband access network systems. PMP systems are used for:

- Green field deployments and network extensions
- Establishing new links instead of leasing services
- Reaching new areas
 - Remote locations
 - Cross over obstructions or right of way
- Providing new services
 - Remote Video Monitoring
 - Broadband access

The following reference architectures are included:

- 1. Network Extensions
- 2. Video Monitoring at a Remote Location
- 3. Remote Area Service
- 4. Extend IP Networks
- 5. High Throughput Data Transfer
- 6. Connect over a Right of Way



Reference Architecture 1: Network Extensions

Network extensions can be quickly deployed without the labor and material cost of laying cable and DSL equipment. Also, new broadband subscribers can be added without requiring grooming of the existing network for broadband services.



Application:

A service provider offers broadband service to a new construction residential community or business campus. Residents have reliable service available faster than wireline alternatives.

The Motorola wireless broadband access network complements the existing broadband network and allows service providers to build incremental extensions. In areas where existing DSL equipment is operating at capacity, it is difficult to cost justify capacity additions for incremental subscriber additions. Service providers have the opportunity to quickly provide broadband service to these customers.

Application:

A carrier provides broadband service to new customers in an area where the DSL network is operating at capacity.

Reference Architecture:

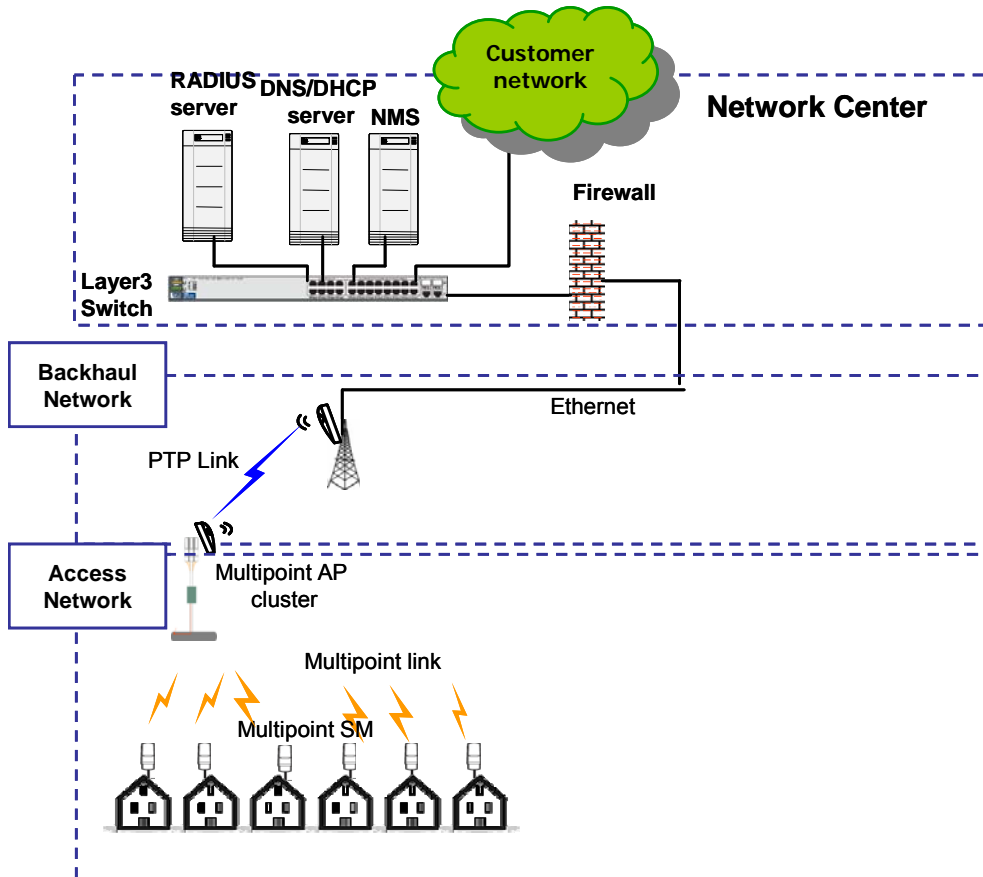

Reference Architecture 2: Video Monitoring at a Remote Location

Because of the low installation cost and ease of relocation, wireless access may be the only viable solution for remote live motion video surveillance, automation control, portable applications or temporary broadband link requirements.

Application:

An International airport installed over 60 full motion cameras using PMP and PTP links to relay sound and video to a center to monitor cameras, gates and phones. The network operator did not have to incur the cost and time to dig a trench or lease T1 services.



Reference Architecture:

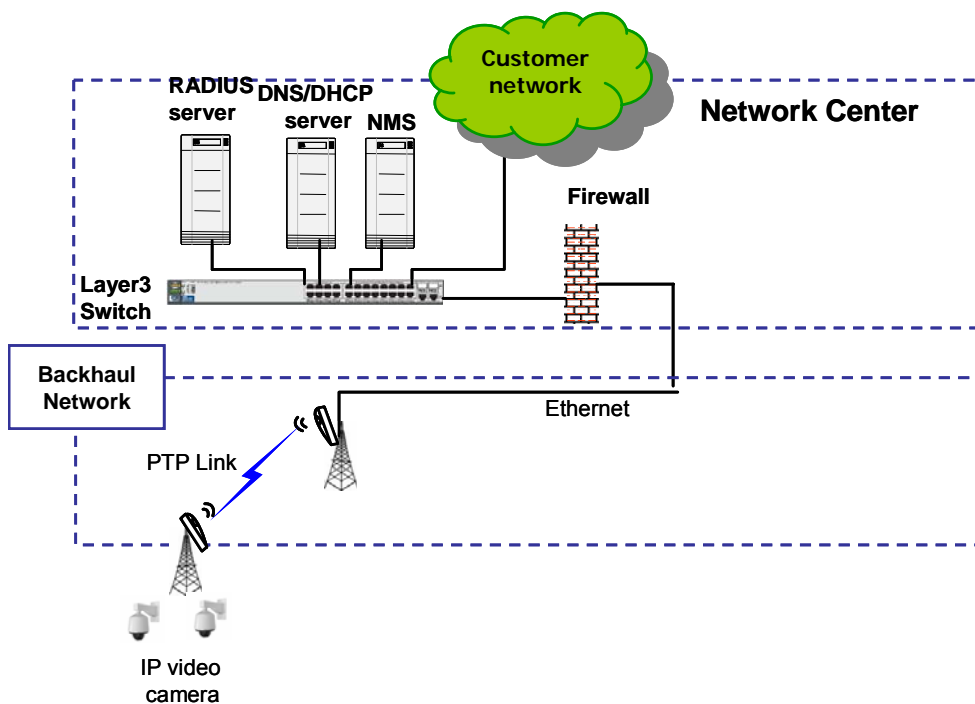

Reference Architecture 3: Remote Area Service

Motorola's wireless broadband access network enables service providers to reach into remote areas quickly without requiring expensive and time consuming network build-outs. The PMP system can augment the existing network to reach out to remote dial-up users.



Application:

A carrier adds broadband network services to an area previously serviced only by dial-up using 900 MHz Subscriber Modules.

Reference Architecture:

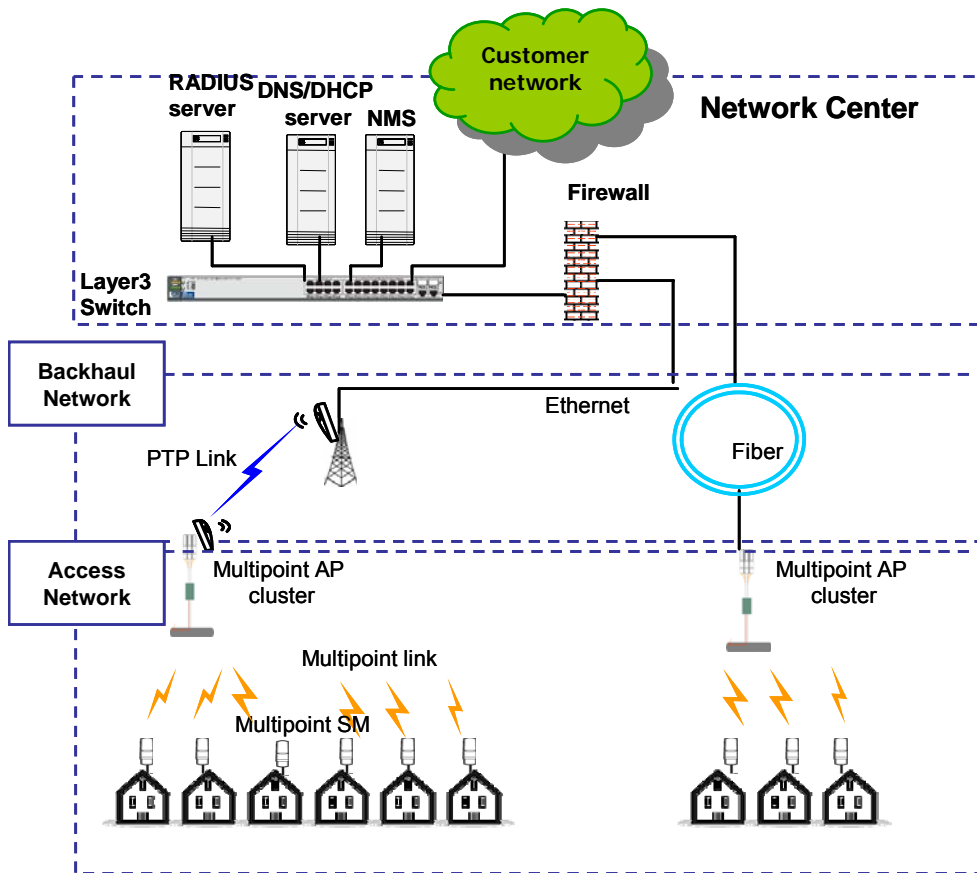

Reference Architecture 4: Extend IP Networks

Provide IP connectivity to buildings not served by broadband or fiber services. The Motorola wireless broadband access network's fast installation time and lower initial and operating costs allow network owners to connect broadband service in a matter of hours.



Application:

Business branch offices in remote locations use PTP and PMP links to share data with the regional center.

Reference Architecture:

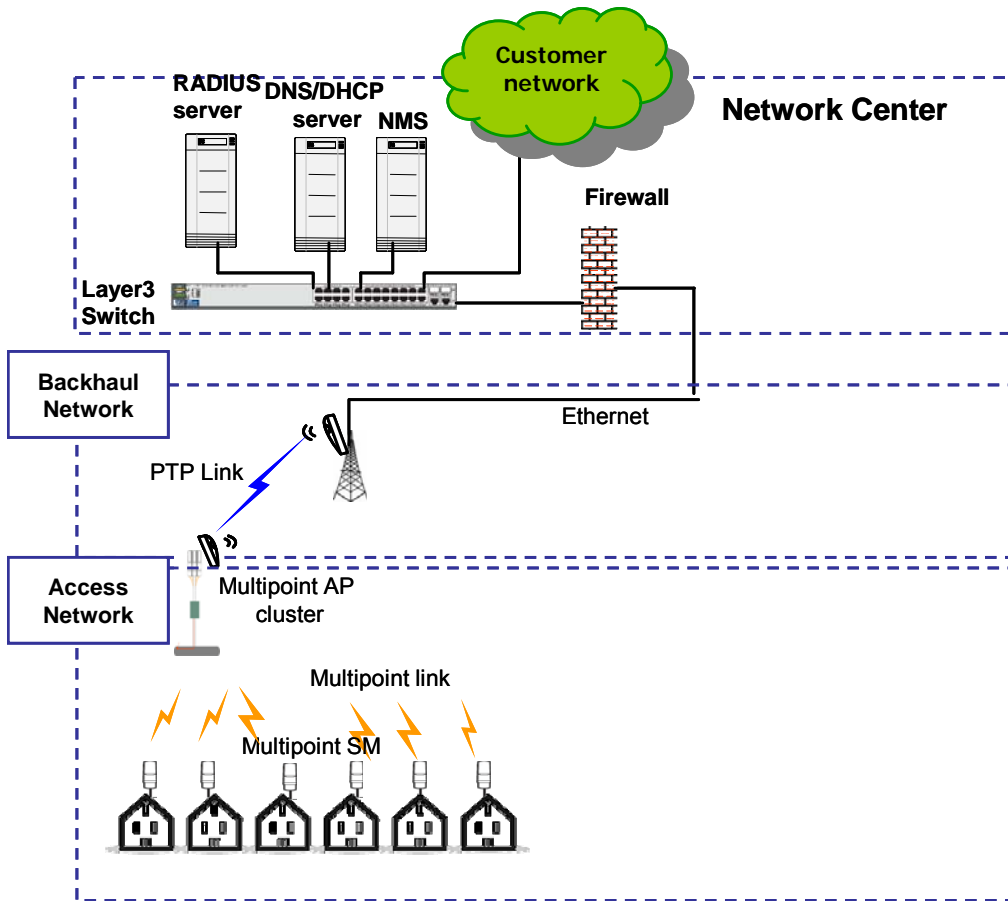

Reference Architecture 5: High Throughput Data Transfer

Provide additional network link capacity to existing locations by adding multiple Motorola wireless broadband PTP and PMP modules to transfer information.

Application:

PTP links enable doctors at five clinics to share information, images and x-rays for diagnostics and consultation.



Reference Architecture:

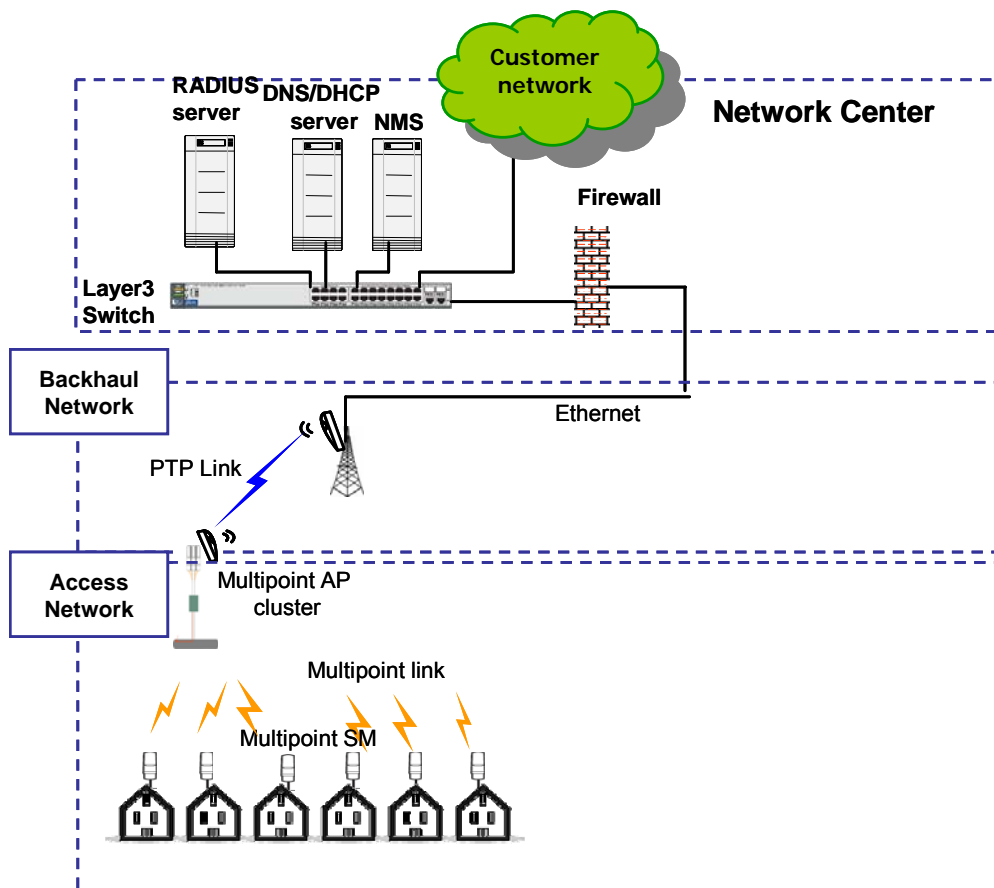

Reference Architecture 6: Connect over a Right of Way

Provide secure, reliable service on long-range, high-throughput LOS, nLOS and NLOS links with varying throughput levels.



Reference Architecture:

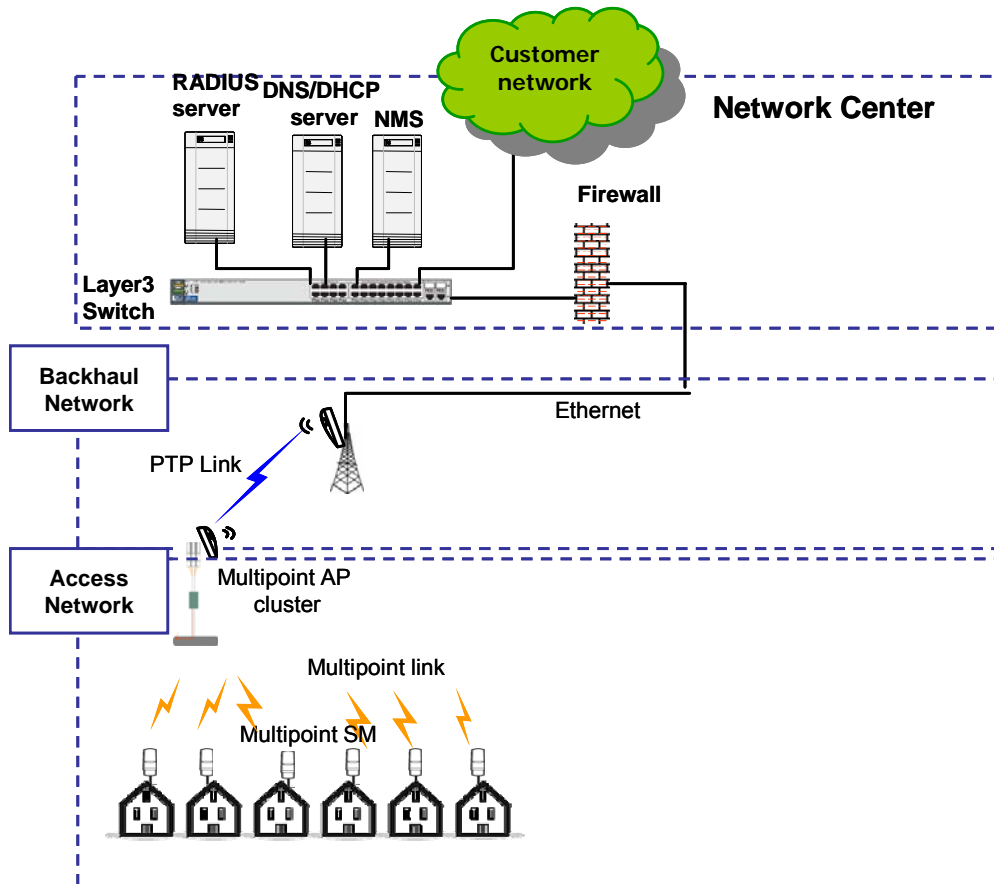

Reliable, Secure Network Extensions for Network Operators

Network owners need to deploy reliable broadband services to meet demand. Network extensions must provide data, video and voice services quickly and efficiently, providing capacity in a “just-in-time” manner. Motorola wireless broadband access networks provide proven secure, reliable broadband service over a wireless connection. Network operators can extend existing networks at a fraction of the cost of wireline alternatives because there is no trenching or waiting to increase network coverage. The wireless network is comprised of point-to-point links and point-to-multipoint access networks which are easily configured to meet specific performance and cost requirements.

Service providers require secure and reliable communications. Motorola’s wireless access networks, with patented signaling technology and military-level security, provide the reliability associated with wireline services with the cost advantage of wireless technology. The PMP system provides an opportunity to efficiently extend the network in areas where the investment required to deploy wireline service is restricting growth.

Requirement	Canopy System Performance
Reliability	<ul style="list-style-type: none"> • Because of its unique signal modulation technique, the PMP system is the most interference tolerant system in the unlicensed spectrum. • Data rate and throughput is consistent to all subscribers – even those at the outer edge of the network.
Installation and Maintenance	<ul style="list-style-type: none"> • Subscriber modules are fast to install. • Built in alignment tools verify installation and minimize truck rolls. • Technical training available to shorten the learning curve for installs and support.
Security	<ul style="list-style-type: none"> • FIPS 197 AES encryption meets Health Insurance Portability and Accountability Act (HIPAA) and military specifications. • Multiple layers of encryption and authentication restrict access to data.
ROI	<ul style="list-style-type: none"> • System payback is in terms of months. • The system scales to deployment levels with low up front investment.

Key Points to Keep in Mind when Designing a Network

- **Quality of Service (QoS):** Motorola wireless broadband access networks provide reliable service because of its industry leading interference tolerance.
- **Capacity:** Motorola's PMP system provides a consistent data throughput to all subscribers. The data rate is consistent for even the most distant subscribers in the network and does not degrade as more subscribers are added to the network.
- **Security:** The PMP system has multiple layers of security with authentication and military-level data encryption to restrict access by unauthorized users.
- **Network Management:** Motorola wireless broadband access networks integrate into existing network management systems through open interfaces from an element manager.
- **Scalability:** With an array of access network modules and a selection of point to point links, carriers can expand their customer base and associated revenue quickly.
- **Reliability:** Motorola wireless broadband solutions are field-proven. All of the configurations and reference architectures in this document are based on actual installations.

Facts and Fiction about Broadband Wireless Access Networks

Network operators who have built their business on reliable service are rightfully concerned about perceptions regarding wireless broadband technology. There are wireless broadband products on the market that do not adhere to the same stringent requirements as the Motorola wireless broadband products and whose performance, reliability and security have led to negative perceptions of interference problems, excessive downtime and loose security.

Concern	Motorola PMP Access Network Deployment Fact
<p>Wireless broadband systems are not secure against hackers and intruders.</p>	<p>Motorola's PMP access network system has multiple security layers including signal modulation technique, authentication and military-level Advanced Encryption Standard (AES) encryption. It is certified FIPS 197 compliant by NIST and meets Health Insurance Portability and Accountability Act (HIPPA) requirements. Motorola solutions provide a level of security that is the equivalent of wireline services.</p>
<p>Wireless broadband systems do not provide the advertised data rate to the maximum range.</p>	<p>Motorola's PMP wireless access network system's unique signal modulation is different from 802.11 systems and allows all subscribers to receive the design bandwidth regardless of the distance from the AP to the SM.</p>
<p>The number of subscribers will load down the system.</p>	<p>Motorola's PMP system scales from an initial deployment to serving dense metropolitan area while maintaining a consistent throughput to all subscribers in the network.</p>
<p>Unlicensed wireless communication is not reliable for quality service.</p>	<p>Motorola's portfolio of solutions includes solutions that operate in both the licensed or unlicensed frequencies. Network operators should choose the technology that best meets their business case.</p> <p>The license-free spectrum is available for use at no charge and is open to many users, and network operators should check a frequency before they use it. The PMP system is unique in that it was designed to be optimized for interference tolerance. The Motorola access network system's synchronization and signal modulation yield an industry leading tolerance to interference.</p>
<p>I don't understand wireless technology enough to deploy it in my network with confidence.</p>	<p>Motorola has deployed wireless technology for decades. Motorola wireless broadband access networks have been deployed to more than one million subscribers in more than 150 countries.</p> <p>Motorola provides training, technical support and will introduce new network operators to an enthusiastic community of users who have experienced the benefit of Motorola wireless access networks for themselves.</p>
<p>Doesn't the weather have an impact on the quality of service I can expect?</p>	<p>Extreme weather can affect communications. Motorola wireless broadband access network modules operate at frequencies that are typically not affected by weather conditions. Motorola PMP systems are field proven in hot, cold, humid, and windy conditions. Refer to the product specification sheets listed on the last page for detailed information.</p>

Network Deployment

With the many different Motorola wireless broadband access network modules, network operators can follow demand when building the network and overlay different frequencies as required. Areas of access network coverage can be linked to the network by Motorola PTP connections.

By co-locating wireless access network AP's of different frequencies, network operators can provide coverage to dense locations while reaching out to remote locations.

Issue	Motorola System Performance	Motorola Benefit
Scalability	Motorola wireless broadband access networks can scale from fewer than 200 subscribers in an area using a single AP to as dense as 4,800 subscribers in an urban area using multiple APs.	The Motorola PMP system provides “just-in-time” scalability so that the investment is made as subscribers are added, not upfront where usage must be anticipated weeks, months or even years in advance. As subscribers are added to the network, data throughput to each subscriber remains consistent.
Traffic Type	Motorola wireless broadband access networks support data, video and VoIP transmissions.	These services provide additional revenue streams.
Security	Motorola wireless broadband networks are available with either AES or DES encryption. All PMP system modules have multiple layers of authentication to restrict access.	Service providers can meet the encryption requirements of municipalities, hospitals and corporate enterprises.
Redundancy	Motorola point to point links are cost effective redundant backhaul links where Ethernet connections are required.	Service providers can offer reliable redundant services at a fraction of the cost of building out the wireline network.
Options	Motorola wireless broadband modules are designed to be tailored to meet specific network requirements. Options for data encryption, passive reflectors and antennas make the system highly configurable.	Network investment is triggered by specific customer demand, lowering initial investment in network facilities.

Network Design Tradeoffs

Motorola wireless access network AP's have the capacity to communicate with up to 200 SM's. AP throughput is divided across the subtending SM's, and priority SMs can be assigned Committed Information Rates (CIR). As the network grows and new SM's are added, network operators can add AP capacity by using an AP of a different frequency.

	Issue	Alternative Solutions
Subscriber Capacity	50 subscribers are connected to a single AP with 4 Mbps downstream capacity, yielding 80kbps downstream when all are active.	Add new subscribers to a different AP frequency to continue provide service at a higher data rate.
Subscriber Range	Subscribers are too far from the AP to provide service.	<ul style="list-style-type: none"> • Add a passive reflector dish at the SM location to extend the range. • Add a passive LENS at the SM location to extend the range. • Install a new AP closer to the subscribers. • Install a remote AP at a subscriber location. • Add distant subscribers at a lower frequency.
Subscriber Throughput	Individual subscribers require more bandwidth to transfer voice, video and data services efficiently.	<ul style="list-style-type: none"> • Set the Maximum Information Rate (MIR) for subscribers to provide an upper transmission boundary for selected network users. • Verify that the IP network architecture is configured to match the flow of data and not a "flat" architecture. • Verify that backhaul links are providing sufficient throughput for associated AP's and not contributing to information "bottlenecks." • Check the number of SM's associated with the AP and consider adding an additional AP at a different frequency. • Consider whether a point-to-point link will meet the needs of high bandwidth users.

System Reliability

With its patented signaling technique, Motorola wireless broadband access networks provide consistent managed throughput to all subscribers and an industry-leading low Carrier to Interference (C/I) ratio. Modules are robust and with GPS synchronization are able to perform even in the most crowded license free frequency bands. Subscribers receive dependable service – even those subscribers at the outer edge of the network.

Motorola provides product support coverage and backs all access network equipment with a one-year warranty.

System Security

All Motorola wireless broadband access network modules are equipped with multiple layers of security to protect IP communication and provide a secure air interface. PMP modules meet Health Insurance Portability & Accountability Act (HIPPA) compliance requirements. Access network products can be equipped with either 56-bit DES encryption or optional 128-bit AES encryption. AES encryption provides the highest level of security, as required for the following types of institutions:

- Banks
- Other financial institutions
- Health care organizations
- Government facilities
- High risk situations with specific security concerns

Motorola Wireless Broadband Industry Awards

Motorola is committed to wireless broadband. We are respected by the industry for innovation, leadership and reliability.

2008	<ul style="list-style-type: none"> • RuraliTIC Award for Innovation in Infrastructure and Services • The Queen's Award for Enterprise in Innovation • Network Products Guide 2008 Product Innovation Award
2007	<ul style="list-style-type: none"> • WiMAX World Europe – Innovation Award for WiMAX CPEi200/300 • NXTComm Award for Innovation • Wireless Broadband Innovation Award • The Queen's Award for Enterprise in Innovation • NXTComm Award for Network Design/Services
2006	<ul style="list-style-type: none"> • Network Computing Well-Connected Award • CTIA Innovation Contest Runner Up
2005	<ul style="list-style-type: none"> • TIA SUPERQuest Award • Network Computing Editor's Choice Award For Best Fixed Wireless System • America's Network Best of WiMAX World
2004	<ul style="list-style-type: none"> • PART15.ORG Manufacturer of the Year

Motorola Support

Warranty

All Motorola wireless broadband access network equipment comes with a one year warranty. Contact a Motorola reseller for more information.

Training

Installation and System Management training is given by Motorola technical specialists. The training is offered either at Motorola's headquarters or as required at field locations.

Documentation

All Motorola wireless broadband access network modules and software releases come with detailed installation and user guide descriptions. These documents are also available on the web. Refer to the last page of this document for a comprehensive list of information available on the web.

Web Support

The Motorola web site provides system users with product information and applications, as well as a venue for wireless access network operators to share applications.

Product Support

Motorola trained support specialists are available to respond to questions should the need arise. Extended warranty coverage is available for PMP system modules.

The Motorola User Community

Motorola wireless broadband access network operators benefit from each other's experience through access to a special knowledge base (<http://motorola.canopywireless.com/kbase/>) web site discussion area and newsletters to keep informed of the latest applications and products.

For More Information

Customer Testimonials

More than 100 case studies are readily available for review at:	http://motorola.canopywireless.com/support/library/case_study.php
---	---

Technical Papers

Performance in Wireless Broadband Systems	http://motorola.motowi4solutions.com/support/library/?region=1&cat=5
Security and the Motorola Wireless Access Networks	http://motorola.motowi4solutions.com/support/library/?region=1&cat=5
Bandwidth and Throughput in Wireless Access Networks	http://motorola.motowi4solutions.com/support/library/?region=1&cat=5
Interference in Wireless Access Networks	http://motorola.motowi4solutions.com/support/library/?region=1&cat=5
Reliable Service in the Unlicensed Spectrum	http://www.motorola.com/staticfiles/Business/Products/Wireless%20Broadband%20Networks/Point%20to%20Multi-point%20Networks/Canopy%20Products/Canopy/ Documents/static%20files/WhitePaper_Unlicense_New.pdf
Understanding Video Image Quality	http://motorola.motowi4solutions.com/support/library/?region=1&cat=5
Dynamic Frequency Selection (DFS)	http://motorola.motowi4solutions.com/support/library/?region=1&cat=5
Voice over IP (VoIP) over PMP access networks	http://motorola.motowi4solutions.com/support/library/?region=1&cat=5

Applications

Video Surveillance	http://business.motorola.com/videosurveillance/index.html
Education	http://www.motorola.com/content.jsp?globalObjectId=8589
Enterprise	http://motorola.canopywireless.com/solutions/enterprise/
Carrier	http://motorola.canopywireless.com/solutions/carrier/
ISP	http://motorola.canopywireless.com/solutions/isp/
Government	http://motorola.canopywireless.com/solutions/metrowifi/

Overview

Canopy System	http://motorola.canopywireless.com/solutions/
Brochure	http://motorola.canopywireless.com/support/library/
MOTOwi4 Solutions	http://www.motorola.com/wi4

Products

100 Series	http://www.motorola.com/statichtml/Canopy_Wireless_US-EN.html
200 Series	http://www.motorola.com/statichtml/Canopy+Advantage_US_EN.html
400 Series	http://www.motorola.com/statichtml/Canopy+400+Series_US-EN.html

Performance Specifications

Access Networks	http://www.motorola.com/business/v/index.jsp?vgnextoid=7cc777c8cd658110VgnVCM1000008406b00aRCRD&vgnnextchannel=926577c8cd658110VgnVCM1000008406b00aRCRD&applInstanceName=default
-----------------	---

PMP Technology

Interference	http://motorola.canopywireless.com/pub_files/InterferenceWhitePaper91602.pdf
Synchronization	http://motorola.canopywireless.com/pub_files/DTSSWhitePaper.pdf
Security	http://motorola.canopywireless.com/pub_files/SecurityFinal_F.pdf
Throughput and Latency	http://motorola.canopywireless.com/pub_files/Performance111503.pdf

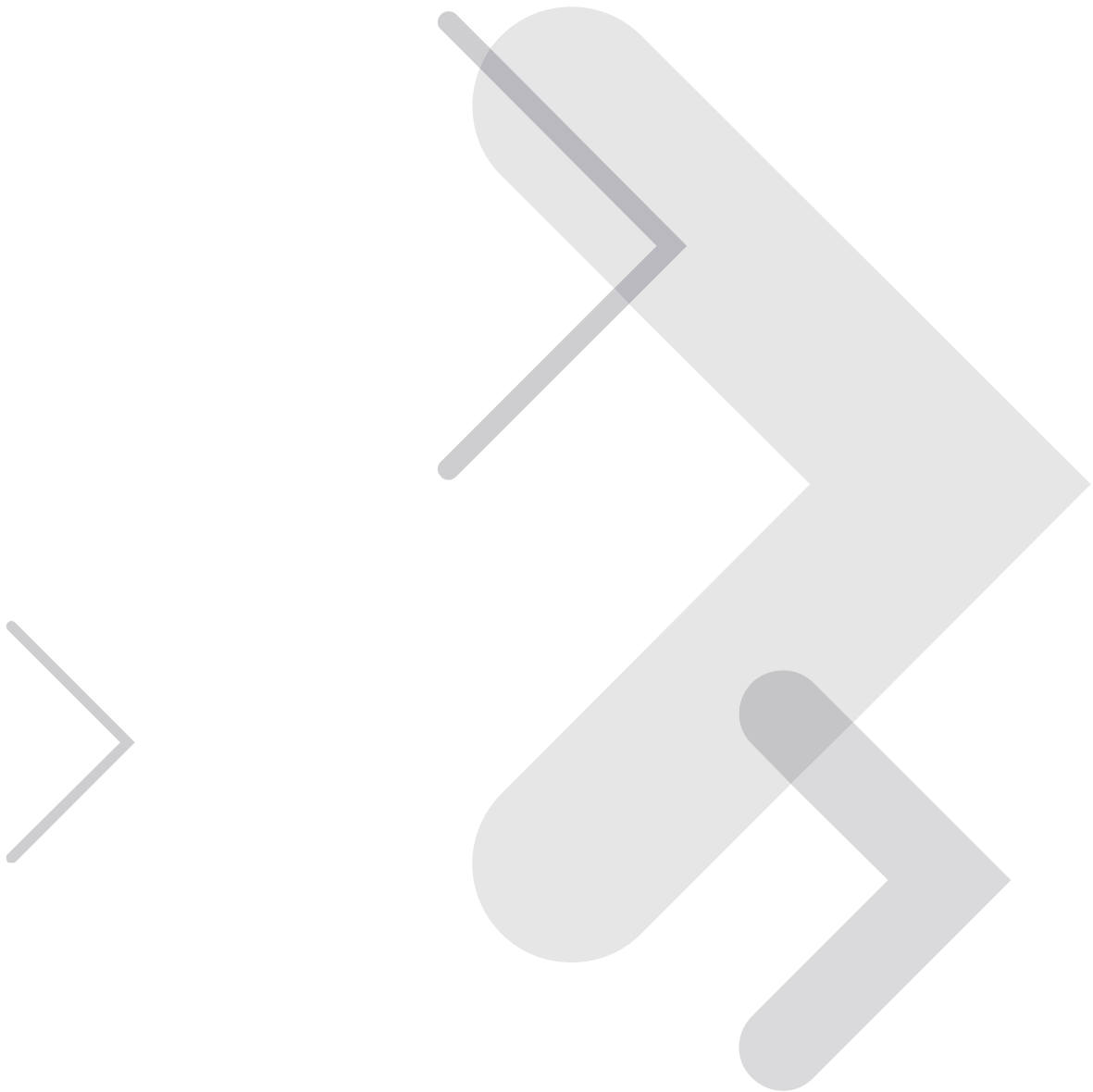

MOTOROLA

Motorola, Inc. www.motorola.com

The information presented herein is to the best of our knowledge true and accurate. No warranty or guarantee expressed or implied is made regarding the capacity, performance or suitability of any product. MOTOROLA and the Stylized M Logo are registered in the U.S. Patent and Trademark Office. All other product or service names are the property of their respective owners. © Motorola, Inc. 2009. This document describes Motorola's Horizon II *micro* Base Station. The official controlled copy of this document is maintained and controlled electronically. Printed versions may be used as reference documents only. This document and the information contained in it is CONFIDENTIAL to Motorola and shall not be used, published, disclosed, or disseminated outside of Motorola in whole or in part without Motorola's consent. This document contains trade secrets of Motorola. Reverse engineering of any or all of the information in this document is prohibited. The copyright notice does not imply publication of this document. © Copyright Motorola, Inc. 2009 ALL RIGHTS RESERVED